



TECHNOLOGY IN MOTION

MACO MULTI

TURN-ONLY AND
TURN&TILT HARDWARE



Operating and maintenance instructions for
Turn, Turn-Tilt and Tilt-Turn windows
END USERS



Contents

Explanations to this manual	3
Intended use and warnings	4
Safety and warning informations	5 - 7
Misuse	8 - 9
Operating instructions	10 - 15
General use informations	16
Cleaning informations	17 - 19
Maintenance instructions	20 - 25
Spare parts, customer service and disposal	26

WARNING

These operating and maintenance instructions are intended for the user (end user) and must be kept for future reference. For safety reasons, all users must be informed of their content.

If it is not certain that the information is available to all users, then a sticker must be attached to the window or a tag must be attached to the handle!

This sticker/tag can be requested from the manufacturer of your window.

This guide is also available at www.maco.eu/us-en/ for download, order number 757758.



Explanations to this manual



DANGER

DANGER indicates a hazardous situation which, if not avoided, will result in **death or fatal injury**.



WARNING

WARNING indicates a hazardous situation which, if not avoided, could result in **death or serious injury**.



CAUTION

CAUTION indicates a hazardous situation, if not avoided, could result in **minor or moderate injury**.

NOTICE

NOTICE is used to address practices **not** related to **personal injury**.



Intended use and warnings

Intended use

For vertically installed windows and casement doors in building construction, window or casement door sashes with MACO turn-only or tilt & turn hardware are brought inward into a turning position or brought inward into a tilted position limited by the scissor stay design using a window handle.

When closing a window sash and when locking the hardware in place, the resistance a small force must be applied so that the profile weatherseal ideally seals.

Functionality restrictions when in open or ventilation positions:

Opened window sashes and casement doors as well as windows and casement door sashes in ventilation position (e.g. tilted position) serve in a shielding capacity only. They do not meet the requirements of:

- › joint tightness
- › sound insulation
- › burglar-inhibiting
- › watertightness
- › thermal insulation

NOTICE

The properties listed only apply for window sashes and casement doors when locked.



DANGER



Any use beyond the range of intended use or other use or processing of the products is considered misuse and can lead to personal injury or property damage!

Safety and warning informations

Safety information

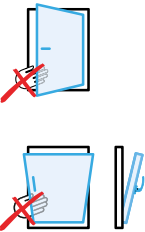
The following symbols illustrate the risks presented by windows and casement doors:

 DANGER	
	Crush hazard <ul style="list-style-type: none">• Moving parts can crush and cut body parts.• Keep body parts clear of moving parts.• Keep children and people who cannot appreciate the risks involved, away from danger zones.

 DANGER	
	Fall hazard <ul style="list-style-type: none">• Death or serious injury will result from falling through opened windows and casement doors.• Do not lean forward or lean out when near open windows and casement doors.• Keep children and people who cannot appreciate the risks involved away from open windows and casement doors.

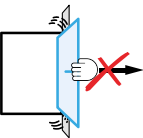
 DANGER	
	Break hazard <ul style="list-style-type: none">• Death or serious injury will result from falling out sash of windows and casement doors through broken hinges.• Do not press the sash against the reveal, the result will be broken hinges.

DANGER

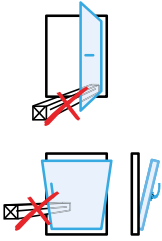

Break hazard

- Death or serious injury will result from damaged sash of windows and casement doors.
- Never put any obstacles between sash and frame.
- Objects stuck between the sash and the frame cause damage to the frame, the hardware and the sash.

DANGER



Break hazard

- Destroyed hardware, frame materials or other components of windows and casement windows cause sash to fall out of its frame.
- Severe injuries or death are caused by a sash falling out.
- Do not subject the sash to additional loads.

WARNING

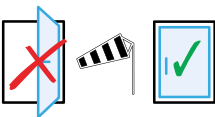

Wind Hazard

- Severe injuries or death are caused by windswept windows and casement doors.
- Close and lock the window or casement door sash in the event of wind and drafts.
- Avoid opening the window and keep all sash closed and locked when winds and storms are forecasted.

CAUTION

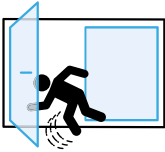

Trip Hazard

- Be alert.
- Watch your step!

CAUTION



Collision Hazard

- Be alert.
- Passage only with fully open sash!

NOTICE

A fixed opening position for window and casement door sashes can only be achieved by means of additional hardware!

Special accessories are available to inhibit windows from slamming in the tilted position, whether due to their position or due to wind or drafts.

You need to order these parts specially when required, please talk to your window supplier.

Misuse

The following illustrations show various misuse operations that must be prevented!

NOTICE

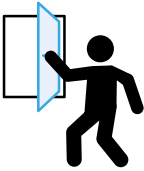

Uncontrolled operation of the sash

- The hardware, frame materials or other components of the window are destroyed.
- The sash has to be guided through its entire range of motion by hand and brought slowly and without resistance to the frame.
- Never operate the sash in an uncontrolled manner.

NOTICE

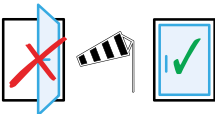

Wind hazard

- The hardware, frame materials or other components of the window are destroyed.
- Never swing the sash open during winds and drafts.
- Always close and lock the door when wind or drafts come up.
- Prevent wind and draft from affecting the window.

NOTICE

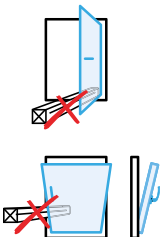

Objects in opening range

- Objects stuck between the sash and the frame cause damage to the frame, the hardware and the sash.
- Never put any obstacles between sash and frame.

NOTICE



Additional loads on the turn & tilt element

- The hardware, frame materials or other components of the turn & tilt element are destroyed.
- Never add any additional load on the sash, under no circumstances.

WARNING

In the event of obvious, or visible damage or improper function, the window or casement door must no longer be operated and must be repaired right away by a certified specialist before any further use!

Claims of any kind arising from damage caused from use that does not correspond to the intended purpose or misuse are excluded.

If in doubt, please ask your window supplier.

The sash fall protection SAFETY PIN is only designed for a one-time protective use!







After using this protective device, all components of the Safety Pin must be replaced! Further use is not permitted!

Operating instructions











Illustrative symbols

The following icons indicate the different possible handle positions and the resulting sash positions of the window and balcony door sashes (proper function).



Tilt & turn hardware

Lever / sash position	Meaning
 	Locked position of the sash (if the room is unattended or no ventilation is desired)
 	Turning position of the sash (for short-term ventilation and rapid ventilation of the room or cleaning the outside windows)
  	Tilted position of the sash (for continuous ventilation of the room)



Tilt & turn hardware with night-vent

Lever / sash position	Meaning
 	Locked position of the sash (if the room is unattended or no ventilation is desired)
 	Turning position of the sash (for short-term ventilation and rapid ventilation of the room or cleaning the outside windows)
  	Opening to a gap or night-vent position of the sash (for longer airing at low outdoor temperatures)
  	Tilted position of the sash (for continuous ventilation of the room)

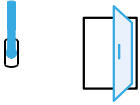

Tilt-first hardware

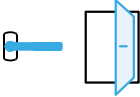
Lever / sash position	Meaning
	Locked position of the sash (if the room is unattended or no ventilation is desired)
	Tilted position of the sash (for continuous ventilation of the room)
	Turning position of the sash (for short-term ventilation and rapid ventilation of the room or cleaning the outside windows)

MULTI SECUAIR - Secured ventilation

Lever / sash position	Meaning
	Locked position of the sash (if the room is unattended or no ventilation is desired)
	Turning position of the sash (for short-term or rapid ventilation of the room or for cleaning the outer panes)
	Tilt position of the sash (for continuous ventilation of the room)
	Secured ventilation position (for reduced, safe continuous ventilation during absence)

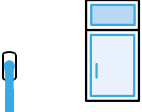
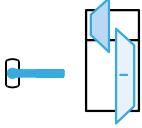

MULTI SKY - hardware for skylight

Lever / sash position	Meaning
	Locked position of both sashes (if the room is unattended or no ventilation is desired)
	Turning position of the central and the skylight sash (for short-term or rapid ventilation of the room)
	Tilt position of the skylight sash (for continuous ventilation of the room)

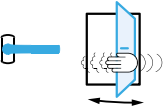
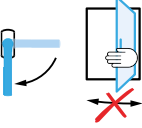
comfort adjuster (locked sash in turning position)

Lever / sash position	Meaning
	Locked position of the sash (if the room is unattended or no ventilation is desired)
	Turning positions of the sash
	

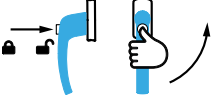
Window handles with locking button or key locking

	Press and hold the locking button to actuate the handle
	Unlock the key to actuate the handle.

Instructions for using French window sashes (2-sashed windows)

Locking and unlocking is done using one or two levers or sliders on the side of the second opening sash. The first sash must be unlocked and opened first using the window handle in order to reach the lever(s) or slider(s).

Faceplate drive gear

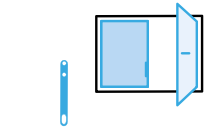
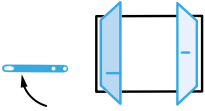
Lever / sash position	Meaning
	Locked position of the sash
	Turning position of the sash

Edge bolt

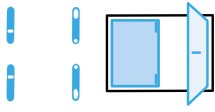
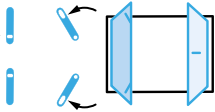
Lever / sash position	Meaning
	Locked position of the sash
	Turning position of the sash

Faceplate lock

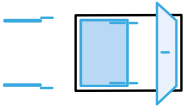
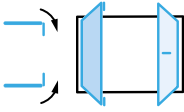
Lever / sash position	Meaning
	Locked position of the sash
	Turning position of the sash

MULTI Zero 2-sash

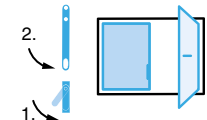
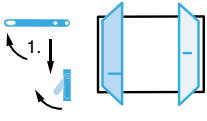
Lever / sash position	Meaning
	<p>Closing position of the sash</p> <p>First, pull and hold the mishandling device towards the sash. Then swing in the lever.</p>
	<p>Turning position of the sash</p> <p>Swing out the lever. The lifting mishandling device is swung out independently.</p>

Notes concerning the opening sequence

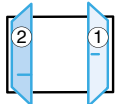
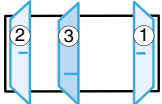
2-sashed windows	
3-sashed windows	

The central sash is always the last sash to be opened!

Notes on the operation of coupled sashes

Aluminium coupled sashes are additional window sashes which are fixed on the outside of the main sash. For cleaning, these two connected sashes can be folded apart.

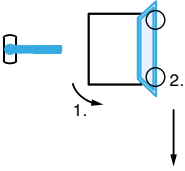
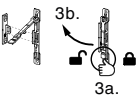
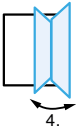
Handle / Sash position	Operation
	Sash in the closed position
	Sash in the turned position
	Releasing the coupled sash
	Sash in the cleaning position

Note on operation of the concealed window rebate valve

Concealed window rebate valves are used for minimum ventilation independent of user action (damp and mould protection). If required, they can be manually locked and unlocked.

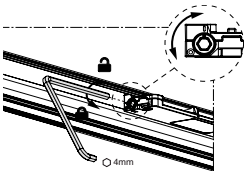
Locking setting	Value
	I = Concealed window rebate valve is unlocked, air inlet is open
	O = Concealed window rebate valve is locked, air inlet is closed

General use informations

A faulty position occurs when the sash allows a turning and tilting motion at the same time (see picture)!

Faulty position:

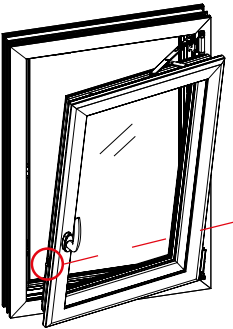

Note on rectifying faulty positions:

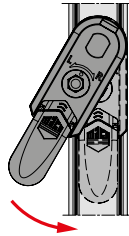

Mishandling device

Should mishandling occur despite the device being installed:

1. Press mishandling device close to the handle in the middle and hold (red arrow - vertical position).
2. Press the sash into the frame on the hinge side, then shift the handle into the tilted position.
3. Now press the sash fully into the frame and turn the handle to the closed position.

General use information:

NOTICE

Risk of damage due to smaller items in the opening area of casement doors. Due to the opening movements, these parts are trapped between the sash and floor, thereby resulting in damage.



Cleaning informations

General cleaning information:

Regular cleaning is a prerequisite for ensuring a long service life and functionality of the equipment. When cleaning the glass surfaces, also check the surfaces of the hardware for contamination and, if necessary, clean with a damp cloth and a pH-neutral cleaning agent. Only close the window or balcony door sash once the cleaned parts have dried.

› Cleaning information for glass surfaces:

Commercially available glass cleaners which are free from ammonium chloride can be used to clean glass surfaces. Detergent solutions, acids or fluoride cleaning agents or abrasives must not be used. Stubborn dirt such as paint splatter and similar can be removed with ethyl alcohol, cleaning benzine or similar.

Only clean glass surfaces with a soft lint-free cloth. Never use microfibre cloths, cleaning sponges, scouring cloths, steel wool, metal and abrasive items or similar – these will scratch the glass surface.

› Cleaning information for weatherseals:

Only use mild cleaning agents to clean the weatherseal. Do not use any dissolving cleaning agents such as acetone, nitro-cellulose thinners, alcohols, acids, alkalis or similar. These dissolve the surface texture of weatherseals. The flexibility of the weatherseals, and thus the service life, can be extended with special cleaning materials for weatherseals (e.g. Vaseline, talc, liquid silicones). These should be applied around once a year. When cleaning the gaskets, repeated and vigorous rubbing must be avoided!

NOTICE

Microfibre cloths contains substances and fibres that can destroy the surface of the glass and the weatherseals. Microfibre cloths are therefore unsuitable for cleaning windows!

Cleaning information for window frames and sashes:

› PVC surface:

In general, PVC surfaces should always be wet-cleaned. Wiping when dry leads to a matt, dull surface due to dust and soiling. Only use soft, lint-free cleaning cloths for cleaning. The products offered as cleaning agents have been specially developed for taking care of PVC surfaces/decorative surfaces and their compatibility has been proven. Cleaning agents containing soap are generally suitable.



Abrasive cleaning agents and cleaning agents containing solvents can scratch or dissolve the surface and therefore must not be used. In the case of heavier soiling, simply give the cleaning agent more time to work. The use of shine sealers can extend the cleaning interval and make cleaning easier. The surface temperature must not exceed 25°C during cleaning. Cleaning agents are available from specialised dealers or the window manufacturer.

› **Timber surface:**

Indoor timber surfaces are best cleaned with a mild cleaning such as diluted washing-up liquid or soap solution. Abrasive and corrosive cleaning agents and cleaning agents containing solvents destroy the painted surface. Only use soft, lint-free cleaning cloths which do not scratch the painted surface for cleaning.

Window cleaning agents contain small traces of alcohol and ammonia. These agents are well suited for cleaning the glass panes and the timber surfaces. Dry the timber profiles after cleaning with a dry, soft cloth, because alcohol can soften the painted surface if left too long.

External surfaces must be cleaned in the same manner as the indoor surfaces. Outside, the surface is more exposed to weathering, such as sunshine, rain, air moisture and temperature.

After a long period and depending on the intensity, this can impair the surface, resulting in very small cracks and similar, for example. This slight damage must be repaired immediately (re-painting) to prevent subsequent, more extensive repairs.

Repairs and repainting of window units must only be carried out by certified specialists.

› **Aluminium surface:**

On aluminium surfaces, dirt that is not too stubborn can be removed using a sponge and water with a neutral cleaning agent, e.g. washing-up liquid, added to it. Do not use any acidic and strong alkaline cleaning agents which attack the surface. Never use abrasive cleaning agents or sponge scourers. Solvents (e.g. acetone, benzine, nitro-cellulose thinners) also damage the surface. Surfaces must not be cleaned in direct sunlight. The surface temperature must not exceed 25°C. Cleaning agents are available from specialised dealers or the window manufacturer.

NOTICE

Abrasive cleaning agents and cleaning agents containing solvents damage the surfaces and must not be used. Only use soft, lint-free cleaning cloths for maintenance. If necessary, test the cleaning agent and cloth in an inconspicuous area (internal rebate area or similar).



Intervals for surface maintenance and cleaning:

The position, weathering and external environmental impacts are key factors when it comes to the frequency of cleaning and maintenance. Therefore, fixed intervals cannot be specified and must be determined on an individual basis. In general, it should be noted that careful maintenance and rapid correction of minor damage can considerably extend the service life.

Maintenance information for hardware components:

To maintain the surface quality of the hardware components for the intended use in the long-term and to avoid deterioration, note the following points:

› Protection against corrosion:

- › Ventilate the hardware and or the rebate areas so that they are not exposed to direct moisture or condensation (important during the construction phase!).
- › Clean the hardware with a moist cloth, avoid permanent wetness!

› Protection against soiling:

- › In general, keep the hardware free from deposits (e.g. salt in coastal areas) and contamination. Immediately remove soiling during construction caused by plaster, mortar or similar with water.
- › Protect hardware and striker plates from contamination (dust, dirt, paint, etc.).

NOTICE

Faulty or damaged parts must be immediately repaired or replaced.

› Protection against corrosive, acidiferous cleaning agents:

- › Clean the hardware with a soft, lint-free cloth and a mild, pH-neutral cleaning agent in diluted form only. Never use aggressive, acidic, solvent-based or abrasive cleaners (scouring pads, steel wool, etc.). This will result in damage to the hardware!
- › If hardware is damaged in this manner, it will impair the function and the safety characteristics, and as a consequence, this can result in personal injury and damage of other items.



Maintenance instructions

Your windows or casement doors are equipped with high quality and durable MACO hardware. The following maintenance instructions and prescribed intervals must be observed and followed in order to ensure that they remain functional and safe for years to come.



NOTICE

In addition to regular cleaning, window and door hardware requires professional, systematic inspection and maintenance to ensure usability and security.

We therefore recommend an appropriate maintenance contract with the manufacturer of your windows and doors.

Inspections and inspection intervals

Verifiable initial inspection **6-18 months** after installation, then every **3-5 years** in private use (**every 3 years for coastal areas up to 10 km inland**) and every **6-18 months** in commercial use (depending on stress intensity)

	 End user	 Certified specialist
Check for free motion of the window or casement door sash and the smooth running and position of the handle in the closed position (precise vertical position downwards) and, if necessary, arranging for a certified specialist to perform readjustment work.	✓	✓
Check the ground clearance of the casement door especially with threshold systems.	✓	✓
Check all hardware and striker plates for obvious damage or wear (abrasion) and, if necessary, arranging for replacement by a certified specialist.	✓	✓
Check all movable hardware and strikers for proper function and lubrication.	✓	✓

Inspections and inspection intervals

Verifiable initial inspection **6-18 months** after installation, then every **3-5 years** in private use (**every 3 years for coastal areas up to 10 km inland**) and every **6-18 months** in commercial use (depending on stress intensity)

 End user	 Certified specialist
---	---

Check fixing screws and tighten or replace as necessary. The fastening screws of the concealed MULTI POWER hardware must not protrude above the baseplate under any circumstances – this leads to damage of the pivot post or scissor stay hinge!	✗	✓
Check sash lifter and adjust or replace as necessary.	✗	✓
Check the adjustment and gasket compression (night-vent) scissor stay as well as the pivot post and corner support.	✗	✓
Check of clamping pressure for the locking cam or i.S. cam and readjust as necessary.	✗	✓
Check gaskets for completeness, function (paper test, incense stick test), elasticity and deformations and replace them if necessary.	✗	✓
Check the Safety Pin (sash fall protection) for any or damage.	✗	✓

DANGER

✗ = must **ONLY** be undertaken by a **certified specialist**, and **NEVER** by the **end user!** Hinging and unhinging of the window sash or casement door sash as well as all adjustments to the hardware must only be carried out by a certified specialist!

The maintenance of safety-related parts (pivot posts and scissor stay hinges) must also only be carried out by certified specialists!



WARNING

In the event of obvious or visible damage or improper function, the window or casement door must no longer be operated and must be repaired right away by a certified specialist before any further use!

The window handle needs to be operated at least once per month in order to maintain smooth operation of the internal fitting.

Lubrication points

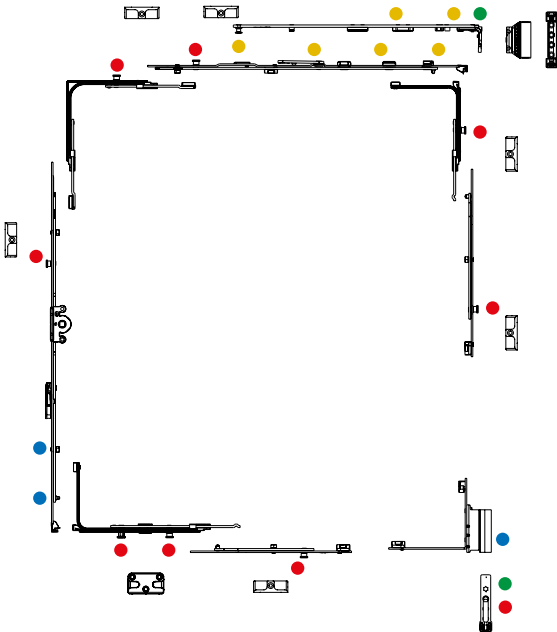

- › The image shown is symbolic. The location and number of lubrication points depends on the actual size and design of the window!
- › Grease for hardware:
Lubricant with PTFE in spray form, for example, OKS 3751 or equivalent (Haberhorn order no. 79937).
- › Lubricant quantity:
approx. 3 mm³ (= size of a pinhead)
- › The fitting must be operated several times subsequent to lubrication in order to properly distribute the lubricant.

Key to lubrication points

- i.S. cams or locking cams:

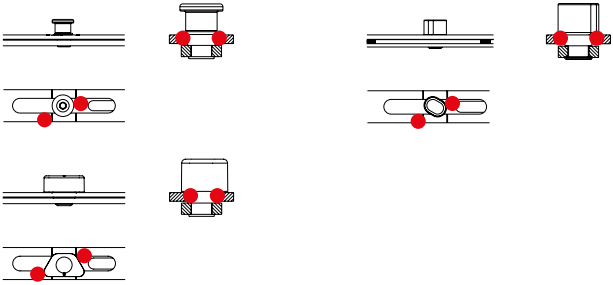

- Anti-slam device for scissor stay or scissor stay restrictor, lateral guide, centre guide:

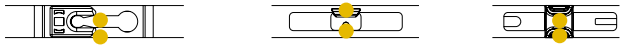

- Striker plates, security striker plates and striker plates for secured ventilation: (optional):

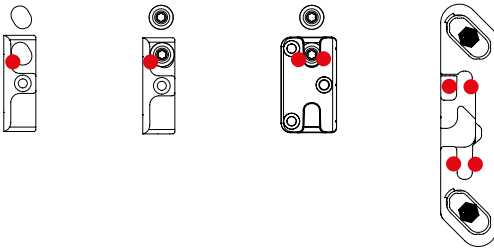

- Tilt lock bolts: (optional)



- Bullet catch:



- Rebated corner support DT160: (optional)

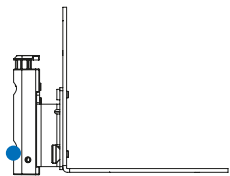

- MULTI POWER:
(concealed fittings)

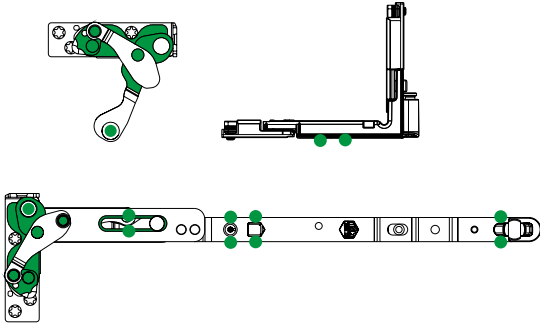

- MULTI SKY (skylight):
Kinematics top and bottom part

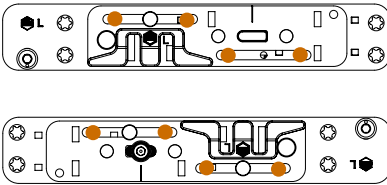

Spare parts, customer service

Spare parts or customer services can be acquired from window suppliers or window manufacturers. A list of manufacturers and dealers can be found at www.macouk.net.



Disposal

Disposal of hardware must comply with local regulations or laws.

Applied standards

ÖN EN 14351: 2010	Windows and doors - product standard
ÖN EN 1191: 2013	Windows and doors - long term performance
ÖN EN 13126-8: 2006	Building hardware for windows and casement doors - Part 8 Requirements and test methods
ÖN EN 1670: 2008	Locks and building hardware - Corrosion resistance - Requirements and test methods

Please send any ideas or suggestions for improving our instructions by e-mail to: feedback@maco.eu



Notes

A large rectangular area filled with a fine grid pattern, intended for taking notes.



MACO near you:

www.maco.eu/contact

Created: 06/2019 - Changed: 07.02.2023

Order no. 757758

All rights reserved and subject to change.

This print document is revised regularly.

The latest version is available at

<https://www.maco.eu/assets/757758>

or scan the QR code.

